

ALL DIMENSIONS IN MILLIMETRES - DO NOT SCALE - PLEASE ASK IF IN DOUBT

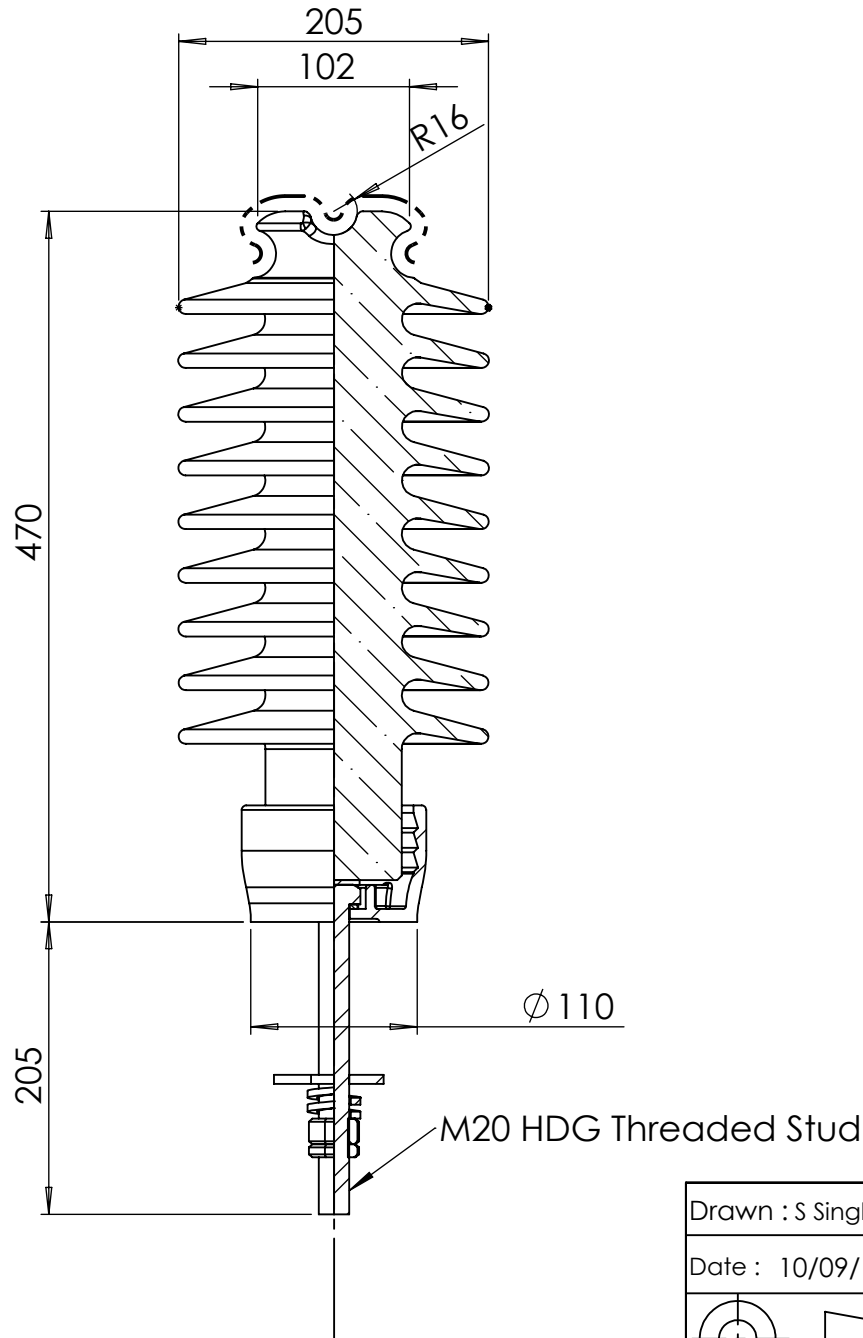

TECHNICAL SPECIFICATIONS

SYSTEM HIGHEST VOLTAGE 36 kV

WITHSTAND TEST VOLTAGES

- a. Power Frequency - wet (vertical) 110 kV
- b. Power Frequency - wet (horizontal) 120 kV
- c. Power Frequency - dry 130 kV
- d. Lightning Impulse - dry (calculated) 200 kV

FLASHOVER TEST VOLTAGES

- a. Power Frequency - wet (vertical) 120 kV
- b. Power Frequency - wet (horizontal) 150 kV
- c. Power Frequency - dry 155 kV

MINIMUM FAILING LOADS

- a. Cantilever (Upright) 12.0 kN

CREEPAGE DISTANCES

- a. Total 1200 mm
- b. Protected 490 mm
- c. Flashover 365 mm

GROSS WEIGHT 16.5 kg

ISSUE	MOD NO	DATE

Drawn : S Singh		New Zealand Insulators Ltd Tel : +64-3-615 085 Fax : +64-3-615 8125 Email - sales@nzinsulators.co.nz
Date : 10/09/19		
	36 kV TIE TOP LINE POST EXTRA HIGH CREEPAGE	D633-0503/A P/N 458201