

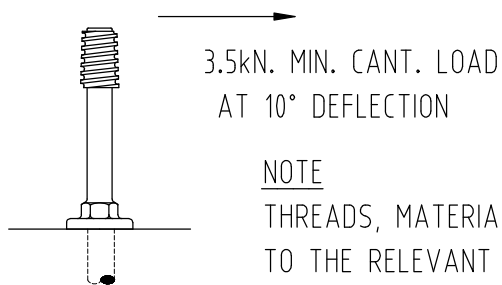

ALL DIMENSIONS IN MILLIMETRES – DO NOT SCALE – IF IN DOUBT ASK

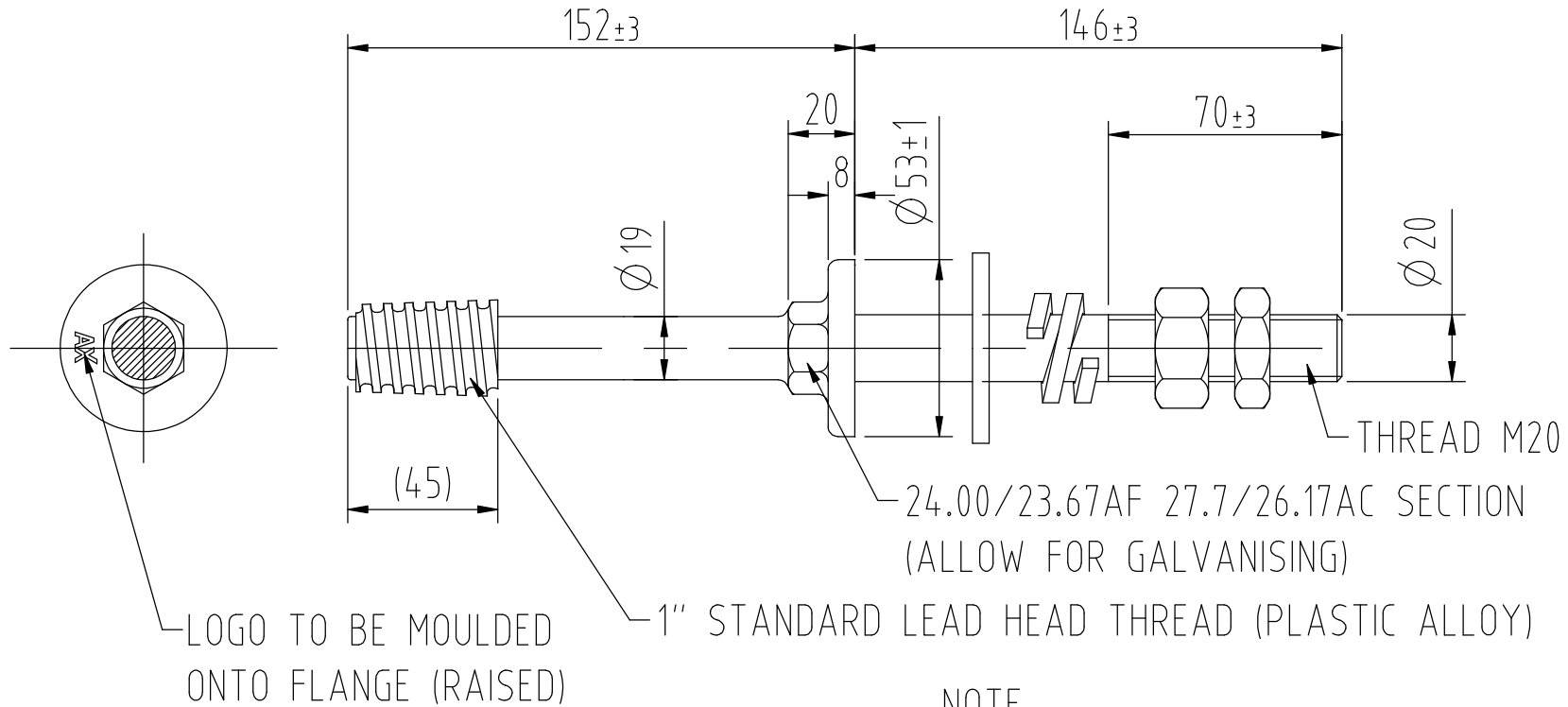

NOTE
THREADS, MATERIALS AND FINISH ALL TO THE RELEVANT NEMA STANDARDS.

NOTE

Each spindle supplied with:-
 One M20 HDG Hex. full nut
 One M20 HDG Hex. thin nut
 One 57x57x5 HDG square flat washer
 One M20 HDG double coil spring washer

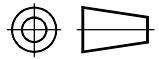
				Drawn J. Bain	 NEW ZEALAND INSULATORS TEMUKA	New Zealand Insulators Ltd. Tel: +64-3-615 0085 Fax: +64-3-615 8125 e-mail: sales@nzinsulators.co.nz
				Date 3.5.2011		
Material AISI 1025 STEEL				 FIRST ANGLE PROJECTION	1" PLASTIC ALLOY HEAD 152/146 INSULATOR SPINDLE	
C	3331	30.06.11	Finish HOT DIP GALVANISED TO ASTM A-153			
B	3328	09.06.11	Tolerance - unless otherwise noted ± 1			
Issue	Mod.N°	Date	Casting Drg.N°	EDP N° 536164	D374-2134/C	