

ALL DIMENSIONS IN MILLIMETRES – DO NOT SCALE – IF IN DOUBT ASK

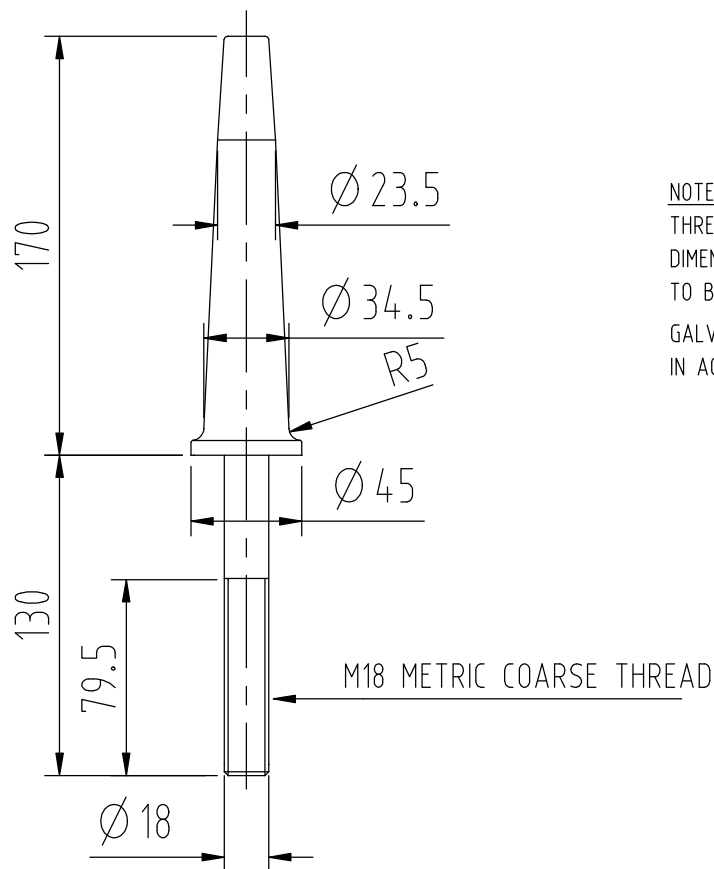

NOTE
 THREAD FORM AND GENERAL
 DIMENSIONS TO CONFORM
 TO B.S.3288 : Part 2 1977
 GALVANISING TO BE TESTED
 IN ACCORDANCE WITH B.S.729

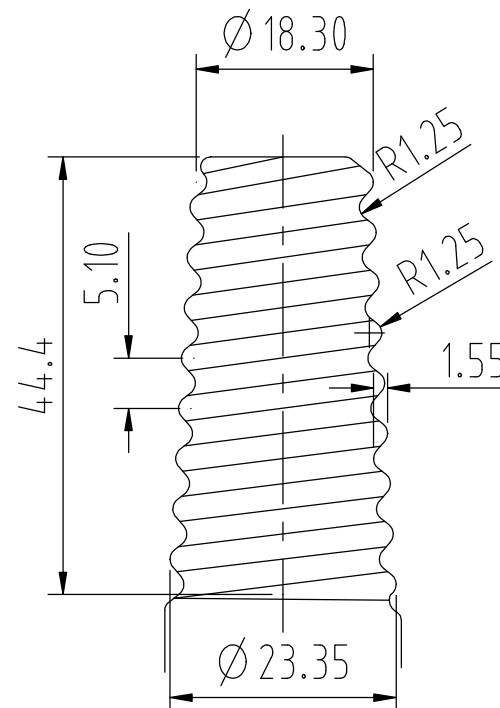

TOLERANCE ON THREAD
 FORM $\pm 0.1\text{mm}$
 (CHECK BY GAUGING)

TO BE SUPPLIED COMPLETE
 WITH:- 2 FULL NUTS
 1 FLAT WASHER

TOLERANCE

UP TO AND INCLUDING 35mm ± 0.7
 ABOVE 35mm $\pm 2\%$

				Drawn J.Bain		NZ Insulators Ltd.	New Zealand Insulators Ltd. Tel: +64-3-615 0085 Fax: +64-3-615 8125 e-mail: sales@nzinsulators.co.nz
				Date 2.4.1993			
Material FORGED STEEL					STANDARD 10kN R23 INSULATOR PIN B.S. SMALL STEEL HEAD THREAD		D374-2027/E
E	3274	9.12.09	Finish HOT DIPPED GALVANISED				
D	2871	9.2.01	Tolerance - unless otherwise noted \pm SEE NOTE				
Issue	Mod.N°	Date	Casting Drq.N°	EDP N° 540528	FIRST ANGLE PROJECTION		