

CODE No.

| NO. | DESCRIPTION | DWG. NO. | MATERIAL | Q'TY | FINISH/SIZE | NOTE |
|-----|-------------|----------|----------|------|-------------|------|
| | | | | | | |
| | | | | | | |
| | | | | | | |

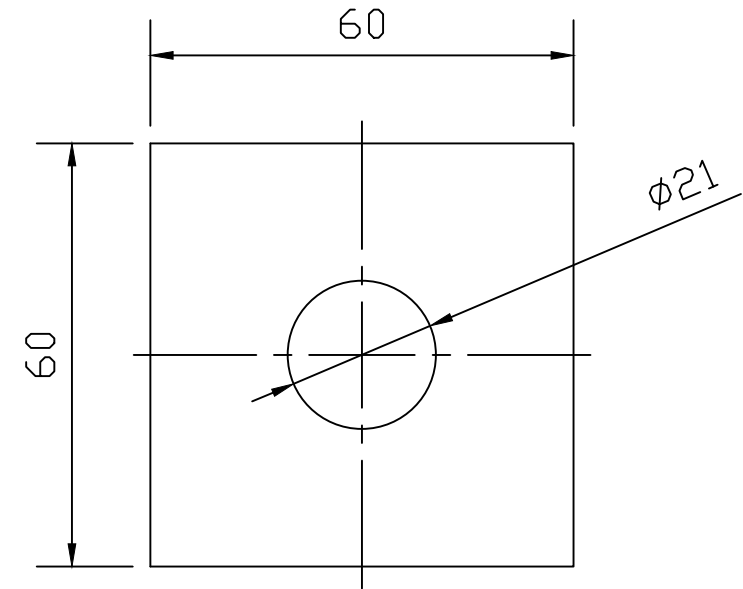
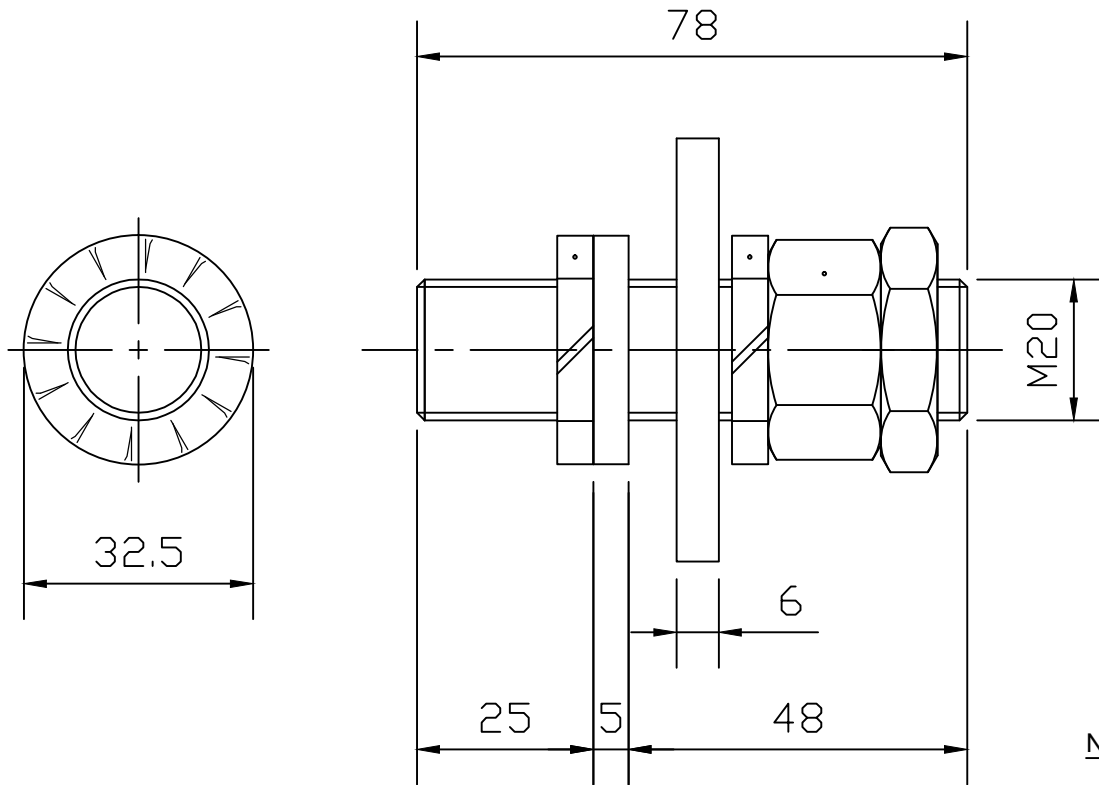

NOTE:

1. THE STUDS ARE MADE FROM FORSED STEEL AND GALVANIZED
2. THE SIZE IS M20 SOLID.
3. THE THICKNESS OF HOT DIP GALVANIZING SHALL BE 50 μm (MIN. AVE)
4. NORMAL TOLERANCE ON ALL DIMENSIONS ARE ACCORDING TO $\pm 5\%$ UNLESS OTHERWISE NOTED.
5. ALL DIMENSIONS ARE MEASURE AFTER HOT GALVANIZED.

| O.S | D.S | Q.A | MF | Purchase | Out Supplier |
|-----|-----|-----|----|----------|--------------|
| | | | | | |
| | | | | | |

| 1 | STUD BOLT | | - | 1 | |
|----|-----------|--|----------|------|----------|
| No | NAME | | Material | Q'ty | Standard |
| | | | | | |

| 1/R | 10/31/2014 | INITIAL RELEASE | J.H.PARK | C.H.PARK | |
|-----|------------|-----------------|----------|----------|---------|
| NO. | DATE | REVISIONS | DESIGNED | APPROVED | REMARKS |
| | | | | | |

| DRAWN BY | DESIGNED BY | CHECKED BY | APPROVED BY | SCALE | DATE |
|-------------|-------------|-------------|-------------|-------|------|
| J.H.PARK | | D.H.YOO | C.H.PARK | 1/1 | |
| OCT.31.2014 | | OCT.31.2014 | OCT.31.2014 | | |

| NAME | Line Post Insulator For Distribution | |
|------|--------------------------------------|--|
| | M20 Stud bolt set(STD48M20) | |

 **DTR CORPORATION**

| REF.NO. | SHEET NO |
|---------|----------|
| | |
| DWG.NO. | |