

NH-Latr 000 R4R4 160A 3 Pole Switch

NZI Part No: 530859
Efen Part No: 34050.0000
Box Terminal 1,5-50mm².
Baseplate Mounting

HQ & FACTORY
THOMAS STREET
PO BOX 5 TEMUKA 7948
T +64 3 615 0085

AUCKLAND SALES OFFICE
2/40 ARRENWAY DRIVE
ROSEDALE 0651
T +64 9 479 4794

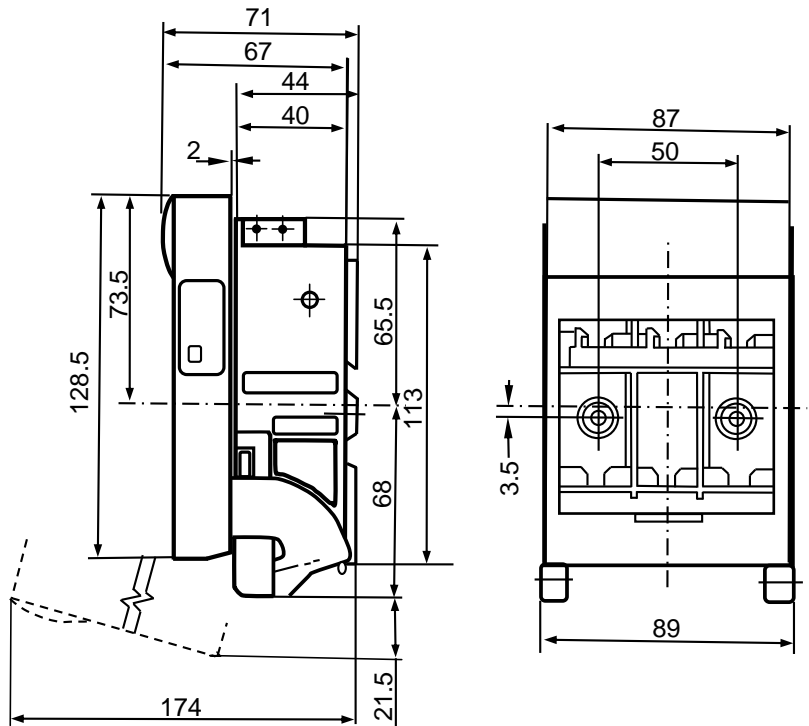

For NH Fuse Links acc. To DIN 43620/1	Size	000	00	1	2	3	4a
Rated operational current I_e	A	100	160	250	400	630	1250 1600 ¹⁾
Conventional free air thermal current I_{th}	A	160	160	250	400	630	1250 1600
Rated operational voltage U_e	V	690	690				
Rated insulation voltage U_i	V	690	800				
Rated impulse withstand voltage U_{imp}	kV	6	8				
Rated conditional short circuit current (When protected by NH fuse links)	kA	80	50				
Utilization Category VDE 0660 T107/EN/IEC 60947-3	$U_e=440V$ AC $U_e=690V$ AC $U_e=440V$ DC ²⁾	AC-22 B AC-21 B DC-21 B					
Mechanical Durability	Cycles	2000	1600	1000	600		
Permissible ambient air temperature	°C	-25 up to +55					
Degree of Protection DIN/EN 60529/VDE 0470 T1	IP	3X					
Maximum Power Dissipation of the NH Fuse Links	Pv max.	9	12	23	34	48	115 140
Weight without NH fuse links	Kg	0.425	0.5	2.0	3.25	5.3	14.0

¹⁾ Utilization category : on demand.

²⁾ $U_e = 220$ V DC/ Fitting of L_1 and L_3 2 Pole; 1 Pole $U_e = 220$ V DC.