

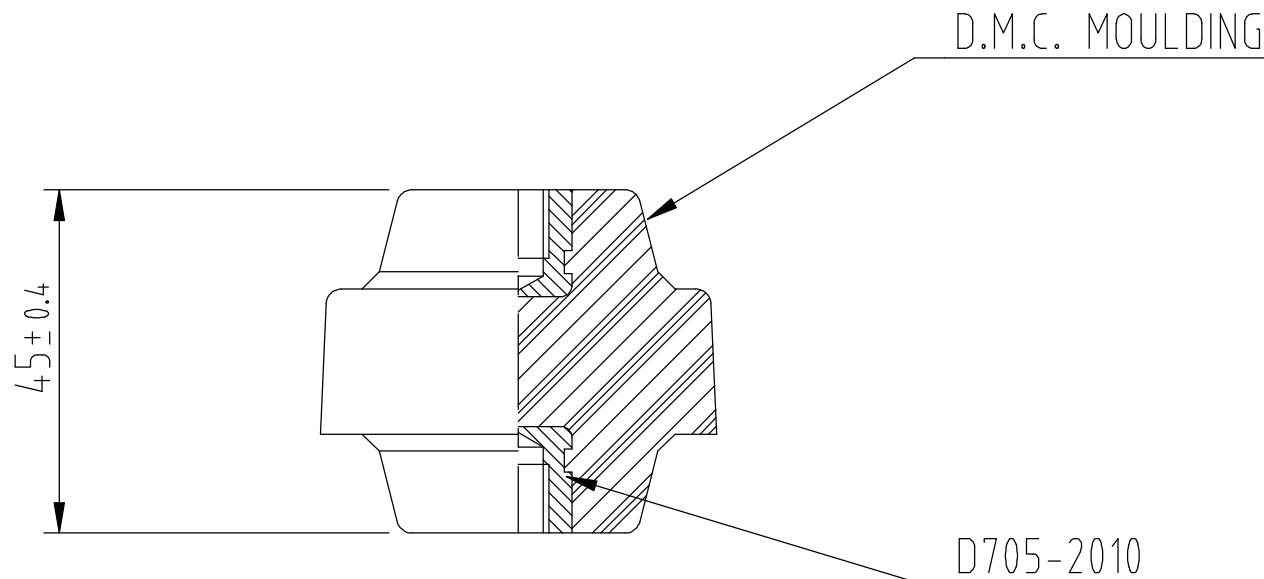

DO NOT SCALE – IF IN DOUBT ASK



Your Quality Partner.

GENERAL NOTES

- 1 ALL MACHINED SURFACES TO BE FLAT AND FREE FROM BLEMISHES AND TO HAVE A SURFACE FINISH AS INDICATED OR BETTER
- 2 ALL CORNERS AND SHARP EDGES TO BE ROUNDED OFF
- 3 CASTINGS TO BE NONPOROUS WHEN PRESSURE TESTED TO 275 kPa (40psi) AFTER MACHINING

						Drawn J.Bain	 NZ Insulators Ltd	
						Ckd		
						Date 27.1.1994	NZI/6/45/M10 STANDOFF M10 STEEL INSERTS	EDP No
						Scale 1:1		515353
						Gen Tolerance	Material DMC	D705-1033/A
Issue	Mod No	Mod	Drn	Date		± 0.4	Finish NATURAL	