

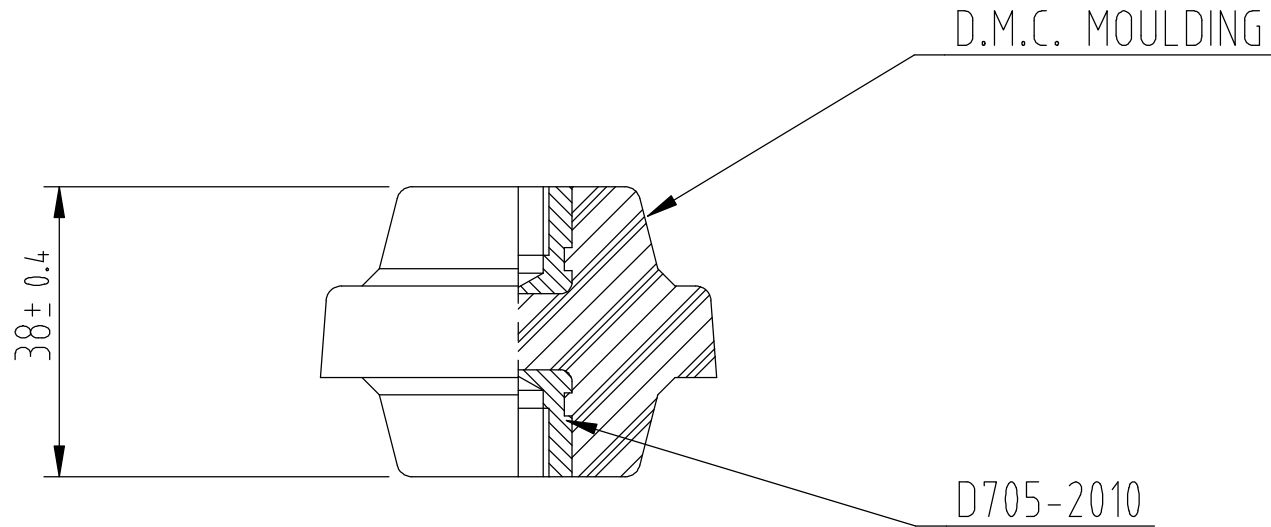

DO NOT SCALE – IF IN DOUBT ASK



Your Quality Partner.

<b>GENERAL NOTES</b> 1 ALL MACHINED SURFACES TO BE FLAT AND FREE FROM BLEMISHES AND TO HAVE A SURFACE FINISH AS INDICATED OR BETTER 2 ALL CORNERS AND SHARP EDGES TO BE ROUNDED OFF 3 CASTINGS TO BE NONPOROUS WHEN PRESSURE TESTED TO 275 kPa (40psi) AFTER MACHINING						Drawn J.Bain	 NZ Insulators Ltd	EDP No 515329
						Ckd		
						Date 27.1.1994	NZI/6/38/M10 STANDOFF M10 STEEL INSERTS	
						Scale 1:1		
					Gen Tolerance	Material DMC	D705-1027/A	
Issue	Mod No	Mod	Drn	Date	± 0.4	Finish NATURAL		