

DO NOT SCALE – IF IN DOUBT ASK

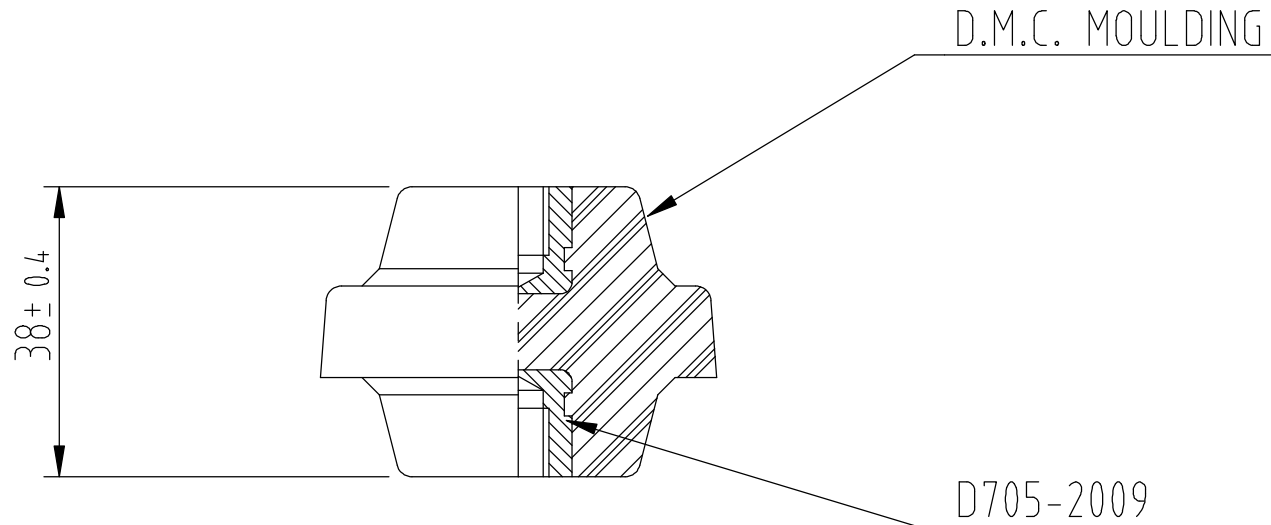

Your Quality Partner.

GENERAL NOTES

- 1 ALL MACHINED SURFACES TO BE FLAT AND FREE FROM BLEMISHES AND TO HAVE A SURFACE FINISH AS INDICATED OR BETTER
- 2 ALL CORNERS AND SHARP EDGES TO BE ROUNDED OFF
- 3 CASTINGS TO BE NONPOROUS WHEN PRESSURE TESTED TO 275 kPa (40psi) AFTER MACHINING

					Drawn J.Bain	<b>NZI</b> NZ Insulators Ltd	
					Ckd		
					Date 27.1.1994	NZI/6/38/M8 STANDOFF M8 STEEL INSERTS	EDP No
					Scale 1:1		515221
					Gen Tolerance	Material DMC	D705-1024/A
Issue	Mod No	Mod	Drn	Date	± 0.4	Finish NATURAL	