

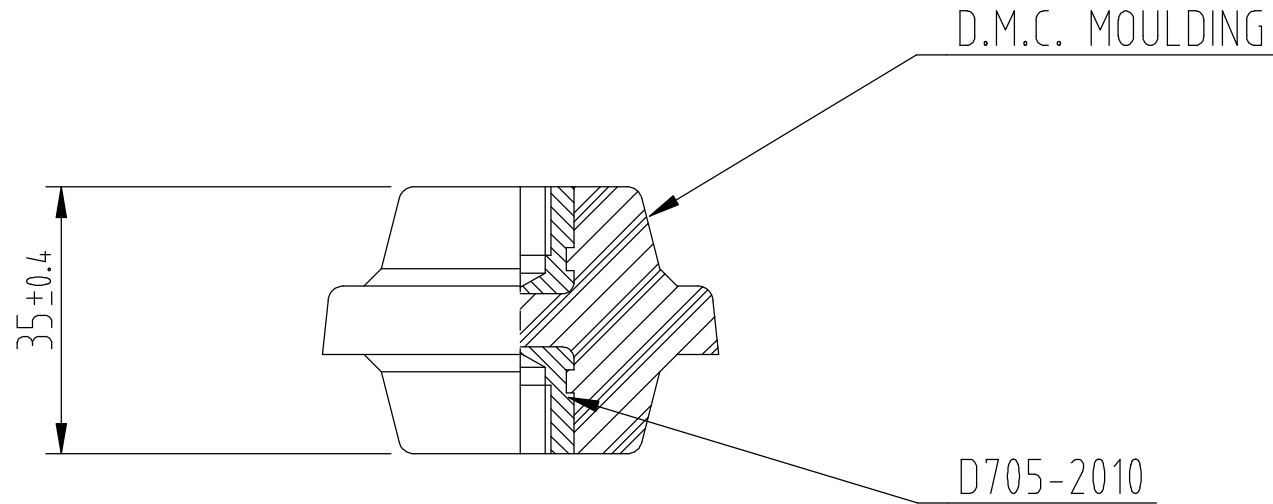

DO NOT SCALE – IF IN DOUBT ASK



Your Quality Partner.

GENERAL NOTES 1 ALL MACHINED SURFACES TO BE FLAT AND FREE FROM BLEMISHES AND TO HAVE A SURFACE FINISH AS INDICATED OR BETTER 2 ALL CORNERS AND SHARP EDGES TO BE ROUNDED OFF 3 CASTINGS TO BE NONPOROUS WHEN PRESSURE TESTED TO 275 kPa (40psi) AFTER MACHINING						Drawn J.Bain	 NZ Insulators Ltd	EDP No 515299
						Ckd		
							Date 27.1.1994	NZI/6/35/M10 STANDOFF M10 STEEL INSERTS
							Scale 1:1	
						Gen Tolerance	Material DMC	D705-1021/A
						± 0.4	Finish NATURAL	
	Issue	Mod No	Mod	Drn	Date			