

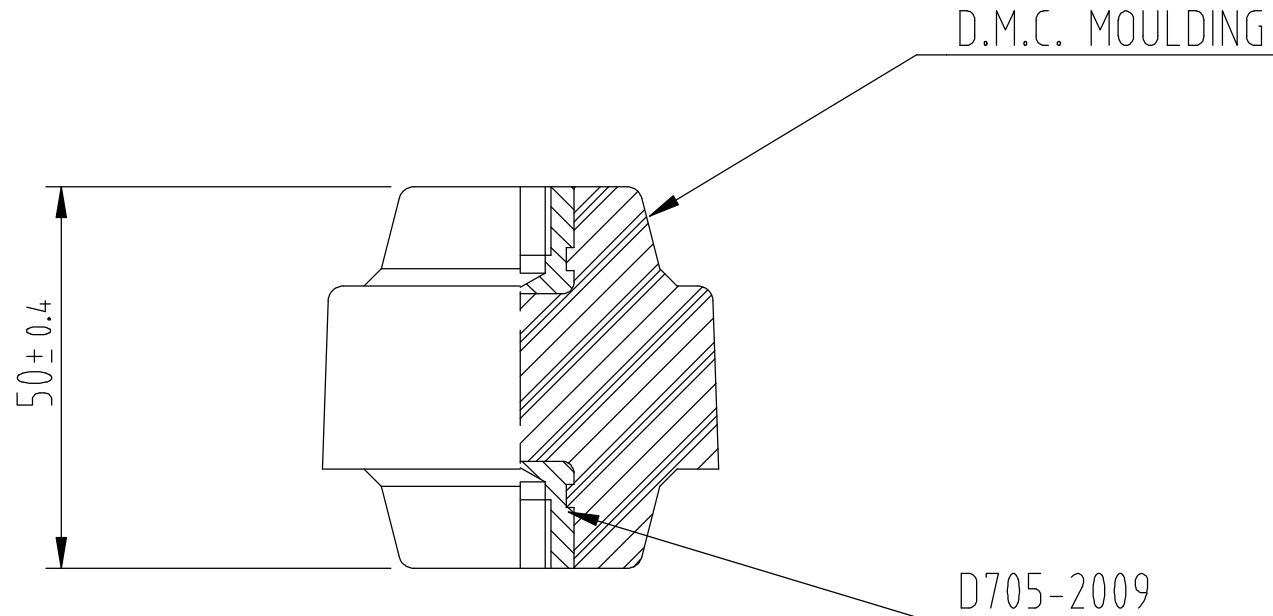

DO NOT SCALE – IF IN DOUBT ASK



Your Quality Partner.

GENERAL NOTES 1 ALL MACHINED SURFACES TO BE FLAT AND FREE FROM BLEMISHES AND TO HAVE A SURFACE FINISH AS INDICATED OR BETTER 2 ALL CORNERS AND SHARP EDGES TO BE ROUNDED OFF 3 CASTINGS TO BE NONPOROUS WHEN PRESSURE TESTED TO 275 kPa (40psi) AFTER MACHINING						Drawn J.Bain	 NZ Insulators Ltd	EDP No 514705
						Ckd		
						Date 26.1.1994	NZI/6/50/M8 STANDOFF M8 STEEL INSERTS	
						Scale 1:1		
	B		CAD			Gen Tolerance	Material DMC	D705-1008/B
	Issue	Mod No	Mod	Drn	Date	± 0.4	Finish NATURAL	